

14

Electrochemistry

Introduction

In this experiment you will observe some spontaneous and non-spontaneous oxidation-reduction reactions, and see how the spontaneous reactions generate an electric current, whereas the non-spontaneous reactions are caused by an electrical current. There is also a quantitative part of the experiment in which you can determine the value of the Faraday (the charge of one mole of electrons), based on the weight loss of a lead anode in an electrolytic reaction caused by a known current for a measured period of time.

Part I. A Galvanic Cell

The reaction you study in this part is:

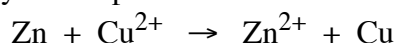

That reaction is spontaneous, so it can act as an energy source. If the two reactants contact each other directly, the only energy given off is heat. If they are not allowed to contact one another directly, but are made part of an electrical cell, so that they can transfer electrons through a wire, the energy given off does electrical work.

Experimental Procedure for Part I

SAFETY PRECAUTIONS: Wear your SAFETY GOGGLES.

WASTE DISPOSAL: All waste from this experiment should be poured into the INORGANIC WASTE containers in the fume hood.

1. *Observing the direct reaction:* Put about 2 or 3 mL of the copper (II) sulfate solution into a test tube; put in a thermometer and measure and record the temperature. Leave the thermometer in the solution, and put some powdered zinc metal (enough to be about one-fourth of the solution volume) into the solution; stir gently with the thermometer. Record all evidence of reaction.
2. Now set up a galvanic cell (“battery”) using the same spontaneous oxidation-reduction reaction of Zn with Cu^{2+} . Separate the two half-reactions so that the

electrons must be transferred by traveling through the wires attached to the electrodes. Attach the wires to a voltmeter, or to a little electric fan, or other device as evidence that your battery is producing electric current. (See Figure 14.1.)

Figure 14.1. Set-up for Part I

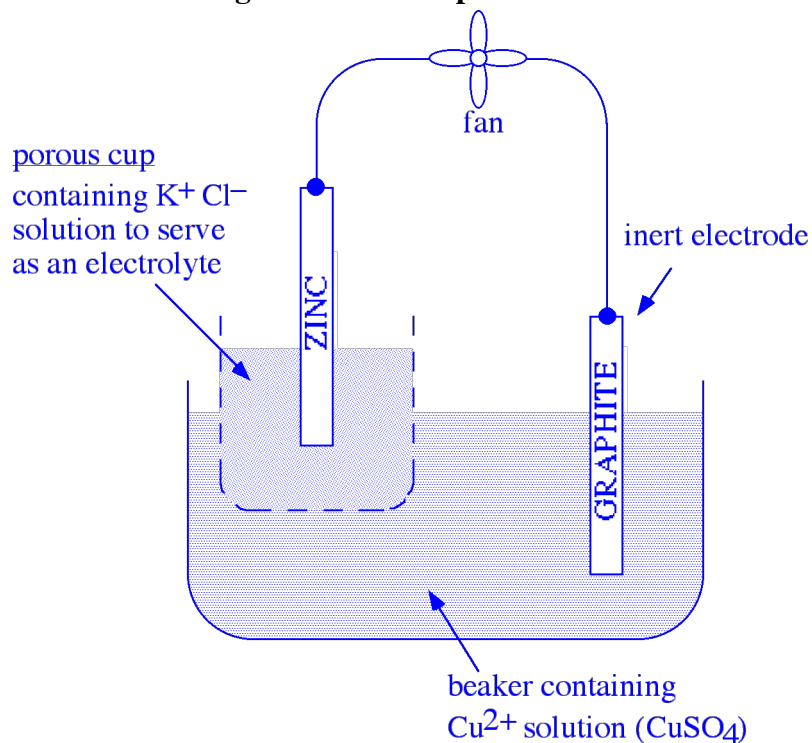

Analysis for Part I

Sketch a diagram of the galvanic cell that you set up, similar to Figure 14.1.

1. Label the anode and cathode, and write the half-reactions that are occurring at each electrode.
2. Which way are the electrons moving through the wire? Show the direction of e^- flow on the diagram.
3. Which way are the positive ions moving through the solution? Why? Show the movement of the Cu^{2+} ions, Zn^{2+} ions, and K^+ ions on the diagram.
4. Which way are negative ions moving through the solution? Why? Show the movement of the Cl^- ions and SO_4^{2-} ions on the diagram.

In this part of the experiment, you observed the same product-favored reaction in two different set-ups. What happened to the energy released by the reaction in each case?

Part II. Quantitative Measurement: Determination of the Faraday

In this part of the experiment you will move Pb from one electrode to another by means of an electric current pushed by a DC power supply. Since a power supply is

necessary, it is classified as an electrolysis, although the net reaction is neither spontaneous or non-spontaneous:

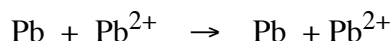

You will use a solution of 0.1 M $\text{Pb}(\text{NO}_3)_2$, with a copper strip as the cathode (-), and a weighed strip of lead as the anode (+). The half reactions are:

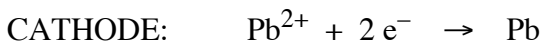

Note that since there is actually no net reaction (no net change), since Pb^{2+} ions are being replaced at the same rate as they are being used up, there is no change in the concentration of Pb^{2+} ions in solution as the process goes on.

The Pb^{2+} ions that form from oxidation of the lead anode are dissolved in the solution as they are created; therefore, the anode loses weight as the electrolysis proceeds. The weight loss is directly proportional to the number of coulombs of charge passed through the solution; i.e., the more electrons that are transferred, the more Pb from the anode goes into solution. As the 2 to 1 ratio in the balanced equation for the half-reaction shows, there are twice as many moles of electrons transferred as moles of Pb removed from the weighed anode. Because of this proportionality, the loss in weight of the anode can be used to determine the charge of a mole of electrons. This is the value of the Faraday.

Experimental Procedure for Part II

SAFETY PRECAUTIONS: Wear your SAFETY GOGGLES. Lead and its compounds are poisonous; use caution in handling them, and wash your hands with plenty water immediately after handling them. In setting up the electrolysis experiment, be careful to follow the directions exactly; do not connect both terminals of an ammeter directly to a power supply.

WASTE DISPOSAL: All liquid waste from this experiment should be poured into the INORGANIC WASTE containers in the fume hood. The electrodes should be rinsed off and returned to the containers where you found them.

1. Take a strip of lead and clean it by covering it with 6 M HNO_3 in a beaker or graduated cylinder. Let it sit in the HNO_3 solution for a few minutes. A slow evolution of H_2 gas should be seen. (The acid first cleans off any lead oxide coating, then starts to react with the lead metal.)

Write the net ionic equation for lead oxide reacting with acid.

Write the net ionic equation for lead metal reacting with acid.

Pour the nitric acid solution off, rinse the lead with water, and then dry it thoroughly with a paper towel. Rub off any surface coating on the lead with the towel until the lead is shiny. When the lead is dry, weigh it as accurately as possible. Record its mass.

- Fill a 250 mL beaker about two-thirds full of 0.1 M $\text{Pb}(\text{NO}_3)_2$ solution. Obtain a power supply, two wires, and a strip of copper. Attach one wire from the negative terminal to the copper strip; attach another wire from the positive terminal to your weighed strip of lead. Suspend the two electrodes at opposite sides of the beaker. Refer to Figure 14.2.
- Turn on the power supply, recording the exact time it was turned on, and adjust the current flow so that it has a steady value between 0.5 and 1.0 amps. Watch the dial and adjust it if necessary, maintaining the same amperage as closely as possible, for about 20 minutes.

As the electrolysis proceeds, lead crystals will form at the cathode, and they tend to stick out toward the anode, shortening the path of current flow, and thus lowering the resistance of the cell; that may affect the current, so that is one reason why you need to monitor and adjust the current. If the crystals of lead extend far enough, they could even make electrical contact with the anode and “short out” the electrolysis (bypass the ion-flow and ion-formation process), so it is a good idea to push the lead crystals downward periodically using a glass rod.

Figure 14.2. Set-up for Part II.

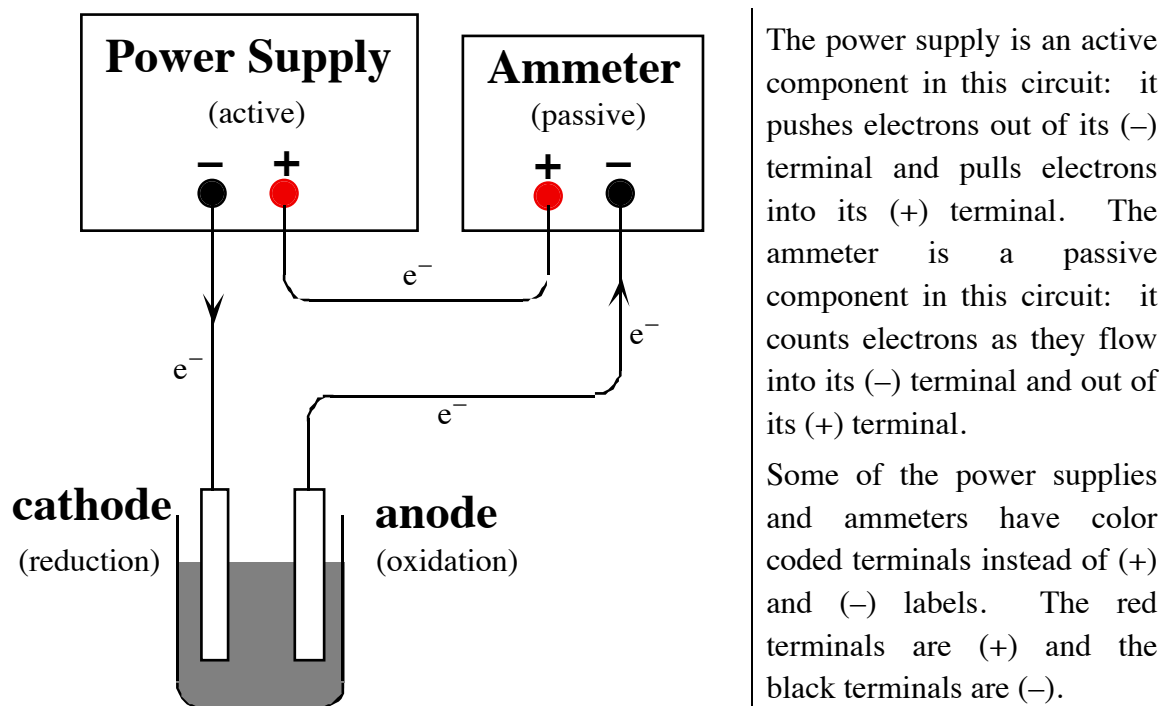

The power supply is an active component in this circuit: it pushes electrons out of its (-) terminal and pulls electrons into its (+) terminal. The ammeter is a passive component in this circuit: it counts electrons as they flow into its (-) terminal and out of its (+) terminal.

Some of the power supplies and ammeters have color coded terminals instead of (+) and (-) labels. The red terminals are (+) and the black terminals are (-).

- Be sure there are no gas bubbles forming at the anode. This would mean that the voltage is too high, such that electrons are being removed from water molecules, forming oxygen gas. If you see gas bubbles, turn down the voltage.

- When the electrolysis has gone for about 20 minutes, turn off the power supply and record the exact time you turned it off. Remove the lead anode, rinse it with water, wipe it thoroughly dry with a paper towel, and weigh it again. Record its new weight and calculate the weight lost during electrolysis.

Calculations for Part II

- Write the net ionic equation for the reaction that occurs during this electrolysis.
- Calculate the mass of the lead that was lost from the anode during electrolysis. Convert this to moles of lead lost, and finally to moles of electrons lost from the lead.
- From the total elapsed time (seconds) of the electrolysis, and the average current (amperes), calculate how many coulombs of charge were transferred during the process.

$$\text{coulombs} = \text{amperes} \times \text{seconds} = \frac{\text{coulombs}}{\text{second}} \times \text{seconds}$$

(If the current could not be held constant, estimate its average value as best you can.)

- Calculate the value of the Faraday (coulombs / mole e^-) from your data.
- Calculate the percent error in your value of the Faraday.
The accepted value is 96485 coulombs / mole e^- .

Part III. Electrolysis Reactions

Electrolysis reactions involve the use of a DC power supply to “push” the electrons in a non-spontaneous direction. The connections for the wires on the power supply are marked (+) and (–) according to whether they are pulling or pushing electrons. Electrons come out of the (–) and into the (+). The wires that you will connect to the power supply have “alligator clips” to connect to the metal strip or graphite rod that you will be using as electrodes. Whichever electrode you connect to the (–) connection of the power supply will be the (–) charged electrode, which supplies electrons for reduction, so it is the cathode. The cathode, in electrochemistry, is defined as the electrode where reduction takes place. The other electrode, which will be (+) charged by being connected to the (+) connection of the power supply, accepts electrons from an oxidation, so is the anode. The anode, in electrochemistry, is defined as the electrode where oxidation takes place.

With the power supply, you will have an ammeter, which reads the intensity of the current flow, in amperes. The power supply has a knob which you can turn that varies the voltage. If the voltage is less than a certain minimum amount (needed for the reaction to be observed), no current flow will show on the ammeter. Once the voltage is turned up to the level necessary for the reaction, the ammeter needle will suddenly jump up to a certain current flow. If the voltage is turned up even higher, the current will increase also (and the reaction will go faster, as more electrons are being transferred per second). However you should avoid turning the voltage up to a value much greater than

the minimum for the reaction, because you could get a complication of having other reactions starting to happen also. The variable voltage knob should be turned to zero (or the whole power supply unit unplugged) except when you are doing an electrolysis experiment. Start the electrolysis process, once the cell is assembled, by turning the variable voltage knob up from zero until the ammeter shows that a current is flowing. When you are finished, turn it back to zero again.

SAFETY PRECAUTIONS: Wear your SAFETY GOGGLES. In setting up the electrolysis experiment, be careful to follow the directions exactly; do not connect both terminals of an ammeter directly to a power supply.

WASTE DISPOSAL: All liquid waste from this experiment should be poured into the INORGANIC WASTE containers in the fume hood. The electrodes should be rinsed off and returned to the containers where you found them.

1. Experimental Procedure for Electrolysis of Potassium Iodide Solution

Pre-Lab Questions for Electrolysis of Potassium Iodide Solution

In this part of the experiment, you will try to figure out what reaction occurs when electrical current is passed through an aqueous solution of potassium iodide. You will consider the half-reactions at the anode and at the cathode separately. The *only* substances available as *reactants* are: $K^+(aq)$, $I^-(aq)$, $H_2O(l)$, $Cu(s)$, and electrons (of course). You can either figure out the possible half-reactions using common sense, or you can select appropriate half-reactions from the table of standard reduction potentials in your textbook.

1. List 3 possibilities for the oxidation half-reaction.
2. List 2 possibilities for the reduction half-reaction.
3. For each of these half reactions, what would you expect to see if it were occurring? What *products* would form? Consider the possibilities of a color change, formation of a solid, formation of a gas (bubbles), a shift in the acid / base balance of the solution (which you could detect using an acid-base indicator), and the formation of elemental iodine (which you could detect using starch solution).

Use two strips of copper as the electrodes; bend them so they will hang on the edge of a beaker (150 mL or 250 mL):

Attach a wire with an alligator clip to each strip of copper. Arrange them so that they are on the far sides of the beaker; if the electrodes touch each other, you'll get a short circuit! (A mild version, since this is a low voltage.) Also be sure the alligator clip does not touch the solution; only the copper electrode should touch the solution; that is because the reaction of copper is one of the possibilities for the reaction at the electrode; if the alligator clip touches the solution, reaction of one or more of the metals in the alligator clip would become a possibility, and you don't know what metals are in the alligator clip.

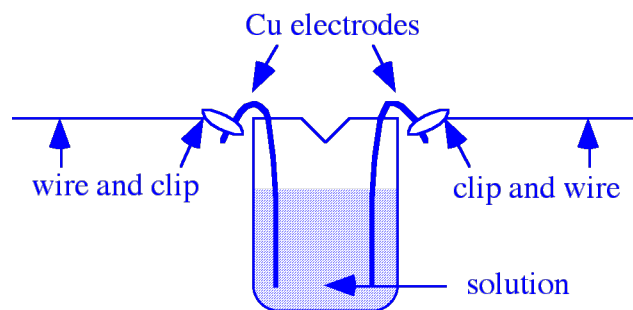

Put some 0.1 M KI solution into the beaker. Connect the wires to the power supply and turn up the voltage until you just barely get noticeable current flow. (That way, you will cause only one noticeable reaction; if you turn the voltage up higher and higher, you will make more and more different reactions possible, and it will get very complicated to figure out what is happening!) Record your observations.

Now see if you can figure out what half reaction is happening at each electrode. The possible reactants present in the solution are: K^+ (aq), I^- (aq), H_2O (l), Cu (s). As you try the following tests, it will help to turn off the power supply when you are not making observations. This will keep the product concentrations small so that you will be able to see what is being produced at each electrode.

Which of the possible half reactions should affect the acid / base balance of the solution? Add an acid-base indicator by the appropriate electrode. Record your observations.

You can use starch solution to test for elemental iodine (I_2). Starch forms a characteristic blue-black color with iodine, even when the concentration of iodine present is still so low that without the starch it would only be a pale yellow. Put a few drops of starch solution by the appropriate electrode. Record your observations.

Analysis for Electrolysis of Potassium Iodide Solution

1. Interpret the results of your test with the acid-base indicator. Is an acid or a base being formed in the reaction?
2. Interpret the results of your test with the starch solution. Is elemental iodine (I_2) being formed?
3. Which of the oxidation and reduction reactions that you listed in the pre-lab question is actually occurring?
4. Look up the E° values for each half reaction. Is the reaction that you observed the one that requires the smallest voltage to make it happen?

Another factor besides E° value actually determines the which half-reaction you will see: the activation energy and thus the rate. If the reaction that required the smallest voltage is very very slow, you will not have seen any appreciable current-flow when you have turned the voltage up to the necessary voltage for that easiest reaction. So, you will

have continued to increase the voltage until it is high enough for another reaction, which goes fast enough to see. Actually at that voltage, both reactions are happening, but you only see evidence of the fast one, as products of the slow one won't show up unless you wait a very long time. Thus you should keep in mind that E° values, like ΔG° values, can only tell you information about whether a reaction is spontaneous or not ("will go" or not) -- but they can't tell you how fast it will go.

This is an important idea, that when there is a choice to be made between two or more reactions, the determining factor is not necessarily which products are most stable; often what matters is the difference in activation energy; i.e., which pathway is easier, so which reaction is faster.

Often the two pathways are parallel, so that the more stable products form via the easiest pathway:

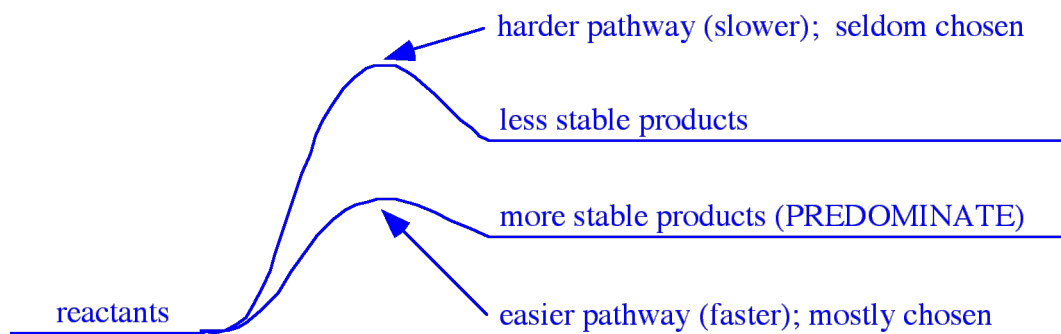

This situation makes you think that product stability determines the choice of which reaction predominates.

However, sometimes the two pathways cross, so that the less stable products form via the easiest pathway. Then the reaction which can predominate is the faster one, even though its ΔG or E value is less favorable:

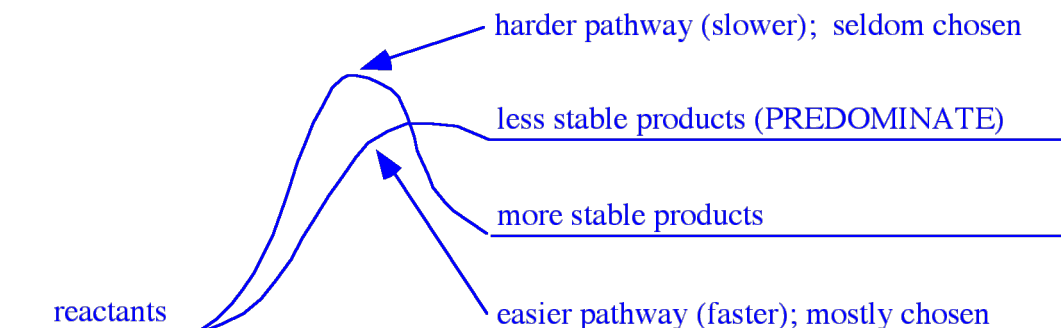

2. Experimental Procedure for Electrolysis of Potassium Nitrate Solution

Pre-Lab Questions for Electrolysis of Potassium Nitrate Solution

In this part of the experiment, you will try to figure out what reaction occurs when electrical current is passed through an aqueous solution of potassium nitrate. You will consider the half-reactions at the anode and at the cathode separately. The *only*

substances available as *reactants* are: K^+ (*aq*), NO_3^- (*aq*), H_2O (*l*), Cu (*s*), and electrons (of course). You can either figure out the possible half-reactions using common sense, or you can select appropriate half-reactions from the table of standard reduction potentials in your textbook.

1. List 2 possibilities for the oxidation half-reaction.
2. List 3 possibilities for the reduction half-reaction.
3. For each of these half reactions, what would you expect to see if it were occurring? What *products* would form? Consider the possibilities of a color change, formation of a solid, formation of a gas (bubbles), and a shift in the acid / base balance of the solution (which you could detect using an acid-base indicator).

Pour out the potassium iodide solution from the previous part, and rinse the beaker and electrodes thoroughly. Reassemble the cell as before, except using 0.1 M KNO_3 solution this time. Turn the voltage up as before, to get current just barely flowing. Record your observations.

What are all the oxidation and reduction half reactions now? The possible reactants present in this solution are: K^+ (*aq*), NO_3^- (*aq*), H_2O (*l*), Cu (*s*). Try testing the solution with appropriate acid-base indicators, and with concentrated ammonia (which makes a deeply colored complex ion with one of the possible products). Record your observations.

Analysis for Electrolysis of Potassium Nitrate Solution

1. Interpret the results of your tests.
2. Which of the oxidation and reduction reactions that you listed in the pre-lab question is actually occurring?
3. Look up the E° values for each half reaction. Is the reaction that you observed the one that requires the smallest voltage to make it happen?